



# Soft&Go

## 151 PLUS

Easily add Soft Serve into any setting with this Compact Countertop model.



**Performance** Peristaltic pump creates a smooth creamy high quality product. Multi-functional LED Display Panel will inform you about: mix temperature, consistency, status, Bag-in-box delivery system can be used, reducing cleaning and set up time. Overrun can be adjustment directly from the front display screen.



**Convenience** Unique Front-loading refrigerated cabinet equipped with a peristaltic pump for simple operation and smooth creamy high quality product production. Optional Interchangeable nozzle available for making soft serve as well as frozen single serving desserts.



**Savings** Vertical ventilation with side intake and top air discharge reduces needed countertop space. Perfect for shops with limited space. C-Stores, restaurants, and coffee shops can easily serve delicious Ice Cream, Frozen Yogurt and plant-based recipes.



**Safety** Visual and Audio alarms alerts operator for a variety of needs: Low mix level, improper loading, cabinet door open, cabinet defrost needed and for eventual machine cleaning.



**Hygiene** Cylinder defrost mode will heat the cylinder and simplify the cleaning procedure.



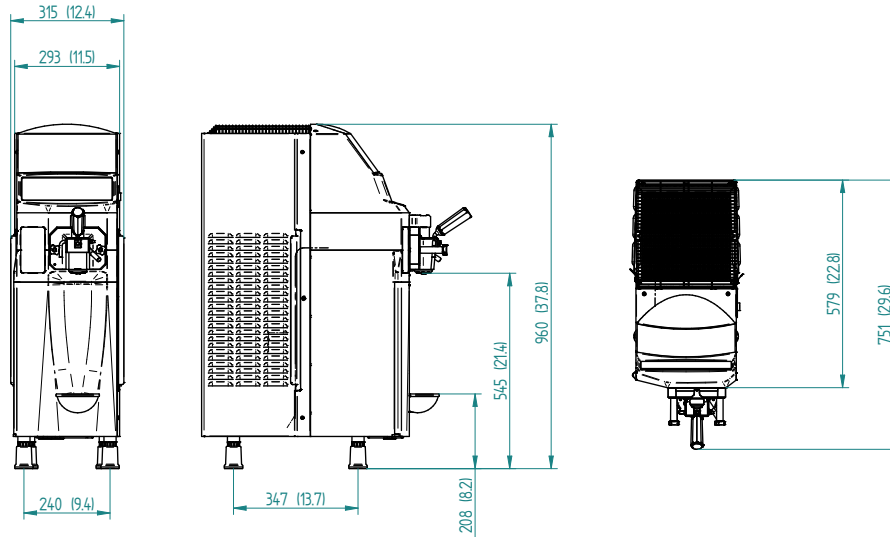

### AIR

Weights	lbs.	kgs.	
Net	209	95	
Crated	238	108	
Volume	cu. ft.	cu. m.	
Volume	11.3	0.32	
Dimensions	in.	cm.	
Width	12.4	31.5	
Depth	22.8	57.9	
Height	37.8	96	
Electrical	Maximum Fuse Size	Minimum Circuit Ampacity	Poles (P) Wires (W)
208-230/60/1 Air	11A	11A	1P, 1W

## Specifications

### Electrical

A dedicated electrical connection is required. Manufactured to be permanently connected. See the Electrical chart for the proper electrical requirements. Consult your local Carpigiani distributor for cord & receptacle specifications as local codes allow.

### Beater Motor

0,7 HP

### Refrigeration System

R404A

### Air Cooled \*

Minimum clearance: 6" (15 cm) on both side panels and 0" (0 cm) from the rear panel for proper air circulation.

### Cylinder Capacity

5.4 quarts (5,1 liters)

All specifications mentioned must be considered approximate; Carpigiani reserves the right to modify, without notice, all parts deemed necessary. This unit may be manufactured in other electrical characteristics and may have additional regulatory agency approvals, please consult the local Carpigiani Distributor. Check name plate for exact electrical data. \* Room temperature 68°F (20°C).

### Bidding Specs

Electrical Volt \_\_\_\_\_ Hz \_\_\_\_\_ Ph \_\_\_\_\_ Neutral  Yes  No Cooling  Air  Water

Options \_\_\_\_\_



738 Gallimore Dairy Road, Suite 113  
High Point, NC - 27265  
Toll free (800) 648 4389

Dealer



[carpigiani.com/us](http://carpigiani.com/us)

an Ali Group Company



The Spirit of Excellence