



191 P/SP

Magica Colore

The automatic self-serve ice cream machine



Performance The Magica is a fully independent, token operated soft serve ice cream & frozen yogurt machine ideal for shopping centers, arcades, & amusement parks. The high performance model can dispense 250 3oz servings per hour. Magica provides three flavor options. One base flavor and 2 flavored choices.



Convenience Magica can serve up to 148 portions before needing a product refill. Equipment cleaning cycle done once every two weeks.



Safety Optional TEOREMA provides remote tracking of servings, cleanings and alerting of service requirements to both service team and operator.



Hygiene Cleaning required every 14 days.



191 P/SP Magica Colore

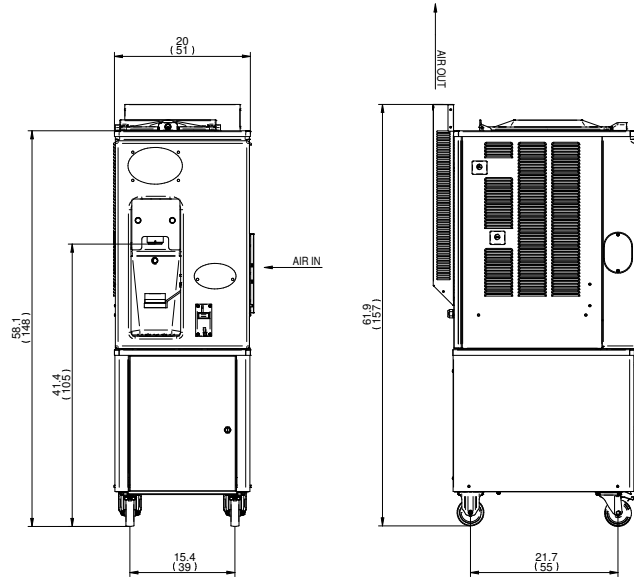

AIR

Weights	lbs.	kgs.	
Net	469	213	
Crated	529	240	
Volume	cu. ft.	cu. m.	
Volume	40.02	1.19	
Dimensions	in.	cm.	
Width	20	51	
Depth	30.4	77	
Height	61.9	157	
Electrical	Maximum Fuse Size	Minimum Circuit Ampacity	Poles (P) Wires (W)
208-230/60/1 Air	30A	25-27A	1P, 1W

Specifications

Electrical

A dedicated electrical connection is required. Manufactured to be permanently connected. See the Electrical chart for the proper electrical requirements. Consult your local Carpigiani distributor for cord & receptacle specifications as local codes allow.

Beater Motor

1,2 HP

Refrigeration System

R404A

Air Cooled *

Minimum clearance: 6" (15 cm) on both side panels and 0" (0 cm) from the rear panel for proper air circulation.

Cylinder Capacity

13 quarts (12,3 liters)

All specifications mentioned must be considered approximate; Carpigiani reserves the right to modify, without notice, all parts deemed necessary. This unit may be manufactured in other electrical characteristics and may have additional regulatory agency approvals, please consult the local Carpigiani Distributor. Check name plate for exact electrical data. * Room temperature 68°F (20°C).

Bidding Specs

Electrical Volt _____ Hz _____ Ph _____ Neutral Yes No Cooling Air Water

Options _____



738 Gallimore Dairy Road, Suite 113
High Point, NC - 27265
Toll free (800) 648 4389

Dealer



carpigiani.com/us

an Ali Group Company



The Spirit of Excellence