



191

BAR E G

Countertop
Soft Serve Model
with heat treatment
for maximum hygiene
and ease of use



Performance The Carpigiani reputation for the smoothest, creamiest soft serve in the market is proven with this powerful, customizable model. High fibrous mixtures can be accommodated in the Gravity-Fed Model.



Convenience Audible Signal alerts when refill is needed. Product is fed from rear of cylinder eliminating need to prime. Least number of components to clean in the industry.



Savings Unique cylinder construction delivers better results using less electricity. Water-cooled & Air Cooled versions available.



Safety TOREMA guarantees facilitated assistance by providing on-line monitoring and diagnosis on a tablet, phone or PC wherever you are.



Hygiene Standby mode maintains safe product temperatures in the freezing cylinder and mix hopper utilizing minimal energy during idle periods.



*Carpigiani Care kit: request it from your dealer to always keep your machine hygienically perfect.

carpigiani.com/us

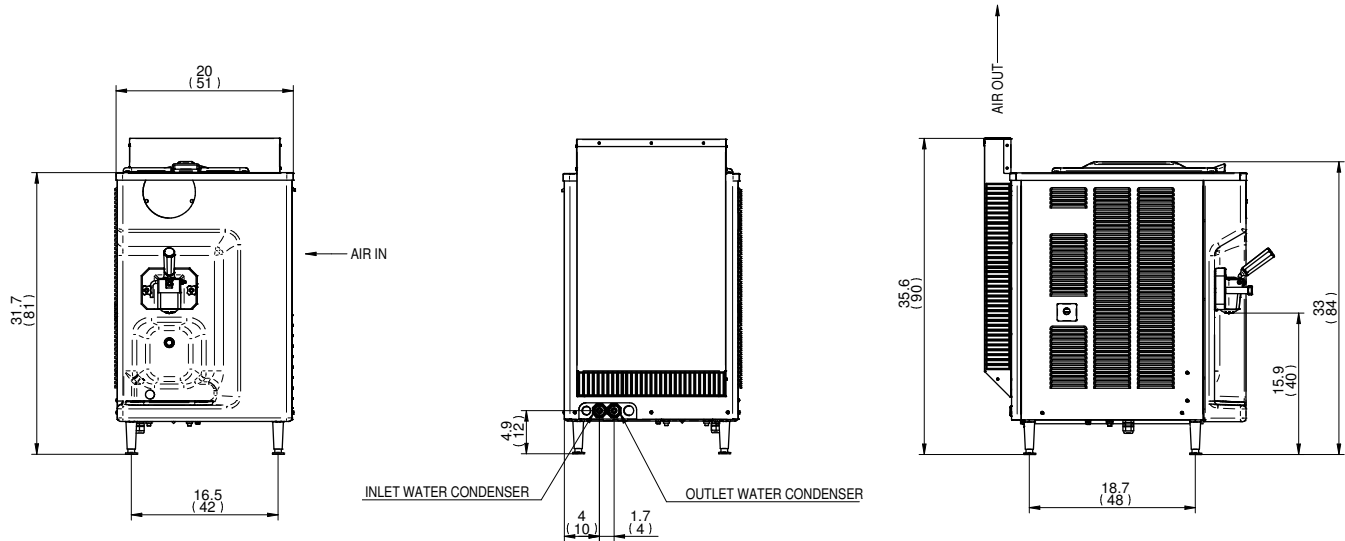

	WATER		AIR	
	lbs.	kgs.	lbs.	kgs.
Weights				
Net	286	130	287	130
Crated	354	161	485	220
	cu. ft.	cu. m.	cu. ft.	cu. m.
Volume	30.01	0.85	30.01	0.85
Dimensions	in.	cm.	in.	cm.
Width	20.01	51	20.01	51
Depth	27.7	70	29.5	75
Height	35.4	90	35.4	90
Electrical	Maximum Fuse Size	Minimum Circuit Ampacity	Poles (P) Wires (W)	
208-230/60/1 Water	30A	25/27A	1P, 1W	
208-230/60/1 Air	30A	25/27A	1P, 1W	

Specifications

Electrical

A dedicated electrical connection is required. Manufactured to be permanently connected. See the Electrical chart for the proper electrical requirements. Consult your local Carpigiani distributor for cord & receptacle specifications as local codes allow.

Beater Motor

1,2 HP

Refrigeration System

R404A

Water Cooled

Water inlets and drain connections in the rear 1/2" MPT

Air Cooled *

Minimum clearance: 3" (8 cm) on both side panels and 0" (0 cm) from the rear panel for proper air circulation.

Tank Capacity

18 quarts (17 liters)

All specifications mentioned must be considered approximate; Carpigiani reserves the right to modify, without notice, all parts deemed necessary. This unit may be manufactured in other electrical characteristics and may have additional regulatory agency approvals, please consult the local Carpigiani Distributor. Check name plate for exact electrical data. * Room temperature 68°F (20°C).

Bidding Specs

Electrical Volt _____ Hz _____ Ph _____ Neutral Yes No Cooling Air Water

Options _____



738 Gallimore Dairy Road, Suite 113
High Point, NC - 27265
Toll free (800) 648 4389

Dealer



carpigiani.com/us

an Ali Group Company



The Spirit of Excellence