



- TASTE THE DIFFERENCE -

## MODEL 30T-RMT

This high volume, front-loading freezer with refrigerated cabinet was designed for high-traffic specialty ice cream and custard stores. The 2 flavor twist machine is great for all mixes, but especially high butter-fat mixes like custard and premium ice creams. Our pressurized machines consistently produce smooth and creamy product. Perfect for full-menu ice cream stores and custard shops.

### The Electro Freeze Advantage

- **Patented Mix Transfer System\*** simplest and most reliable pressurized system available
- **Flexible Mix Holding System** pumps directly from bags or from mix containers
- **The Finest Frozen Product**, consistently the best frozen product available. Smooth, creamy and profitable
- **Self Closing Spigots** prevents the mess and eliminates waste
- **Adjustable Dispense Rate** set to meet your specific dispensing speed and volume requirements
- **Exclusive Auger Design** gently blends, reducing agitation, maintaining product quality and consistency.
- **Energy Conservation Mode** reduces energy cost and holds product safely during non-business hours
- **Superior Low Temperature Refrigeration System** provides the best in class production and product quality
- **Product Flexibility** serves a variety of frozen products, custard, ice cream sorbets, water ice or yogurt
- **Experience Tells** Electro Freeze has been manufacturing quality frozen treat machines since 1929. Superior engineering, product innovations, sturdy construction, quality craftsmanship and dependable performance are Electro Freeze hallmarks.
- **Superior Service Support** backed by a world-wide distributor network

\*U.S. Patent #5,349,825

## PRESSURIZED SOFT SERVE FREEZER

### Freedom 360° Series



[electrofreeze.com](http://electrofreeze.com)

FOR MORE INFORMATION CONTACT

800-755-4545 • [sales@electrofreeze.com](mailto:sales@electrofreeze.com)

# 30T-RMT Soft Serve Freezer

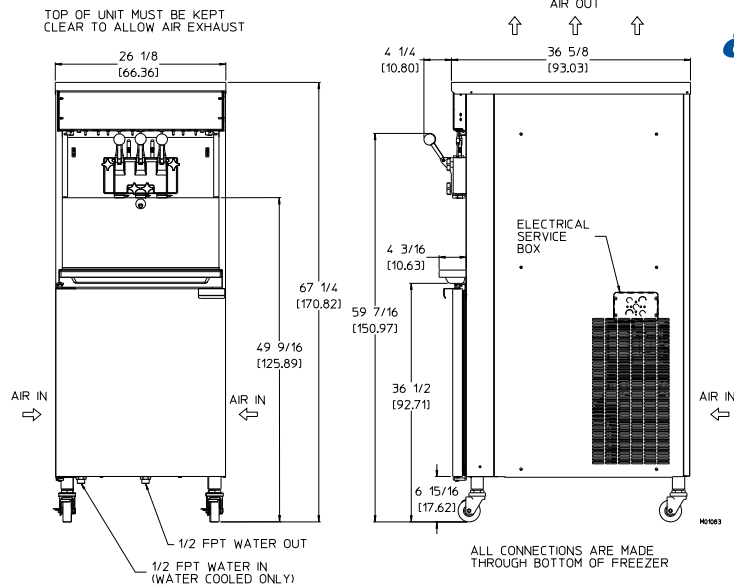

## MODEL 30T-RMT SPECIFICATIONS

Due to continual product improvements all specifications are subject to change without notice.

Weights	lbs.	kgs.	
Net	847	384	
Crated	965	437	
	cu.ft.	cu.m.	
Volume	58.42	1.65	
Dimensions	in.	cm.	
Width	26-1/8	66.36	
Depth	36-5/8	93.03	
Height	67-1/4	170.82	
Electrical	Maximum Fuse Size (Qty)	Minimum Ampacity (Qty)	Poles (P) Wires (W)
208-230/60/1 Air	35 (2)	27 (2)	2P, 2W
208-230/60/1 Water	30 (2)	24.5 (2)	2P, 2W
208-230/60/3 Air	25 (2)	19 (2)	3P, 3W
208-230/60/3 Water	20 (2)	16.5 (2)	3P, 3W
	Total Amps (Qty)		Poles (P) Wires (W)
400/50/3 Air	10.7 (2)		3P, 4W
400/50/3 Water	8.5 (2)		3P, 4W

Electrical characteristics other than above available on request from factory or local distributor. Check nameplate for exact electrical data.

### Bidding Spec

Electrical: Volt \_\_\_\_\_ Hz \_\_\_\_\_ Ph \_\_\_\_\_  
 Cooling: \_\_\_\_\_ Neutral \_\_\_\_\_ Yes \_\_\_\_\_ No \_\_\_\_\_  
 Options: \_\_\_\_\_

**Electrical**  
 Two dedicated electrical connection are required. Manufactured to be permanently connected. See electrical chart for the proper requirement. Consult your local electrical codes for cord and receptacle specifications.

**Beater Motor**  
 Two, 2 hp.

**Refrigeration Systems**  
 Two, 9300 Btuh. R404a.

**Air and Water Cooled**  
 6" (15.2 cm) air space required at rear panel or both side panels and 18" (45.7cm) air space above unit for proper air circulation.

**Mix Tank Capacity:** two - 26 quarts (24.6 liters) each  
**Freezing Cylinder Capacity:** two - 5 quarts (4.7 liters) each

Certified and/or listed by:



\*UL listed and listed by Underwriters Laboratories under Canadian National Standard C22.2 No. 120-M91 (R2008)  
 \*\*Select Voltages @ 50HZ



**Electro Freeze div. of H.C. Duke & Son, LLC**  
 2116-8th Avenue, East Moline, Illinois 61244 USA  
 Phone (309) 755-4553 • (800) 755-4545  
 FAX (309) 755-9858  
 E-mail: sales@electrofreeze.com • www. electrofreeze.com

**Authorized Distributor**