



- TASTE THE DIFFERENCE -

MODEL CS600

This high-volume, single-flavor counter model soft serve freezer is easy to operate and simple to clean. The CS600 provides menu flexibility for convenience stores, specialty buffets, airport kiosks, burger restaurants, diners and ice cream stores.

The Electro Freeze Advantage

- **The Finest Frozen Product** consistently the best frozen product available. Smooth, creamy and profitable
- **Patented auger** gently blends reducing agitation and maintaining product quality and consistency.
- **Consistency Control** designed to dispense the finest frozen product available
- **Air Filter** washable filter keeps the condenser clean
- **Compact design** with a small foot print.
- **Experience Tells** Electro Freeze has been manufacturing quality frozen treat machines since 1929. Superior engineering, product innovations, sturdy construction, quality craftsmanship and dependable performance are Electro Freeze hallmarks.
- **Superior Service Support** backed by a worldwide distributor network

Optional

- **Top Air Discharge Chute** the top air discharge chute on air cooled models allows units to be set side by side and air flow to be diverted up.
- **Cabinet** an optional commercial grade stainless steel cabinet is available includes heavy duty casters, a sturdy latch and gives you 6 cubic feet of storage.

GRAVITY SOFT SERVE FREEZER

Compact Series

Single Flavor



Shown with Optional Cabinet



CS600 Soft Serve Freezer

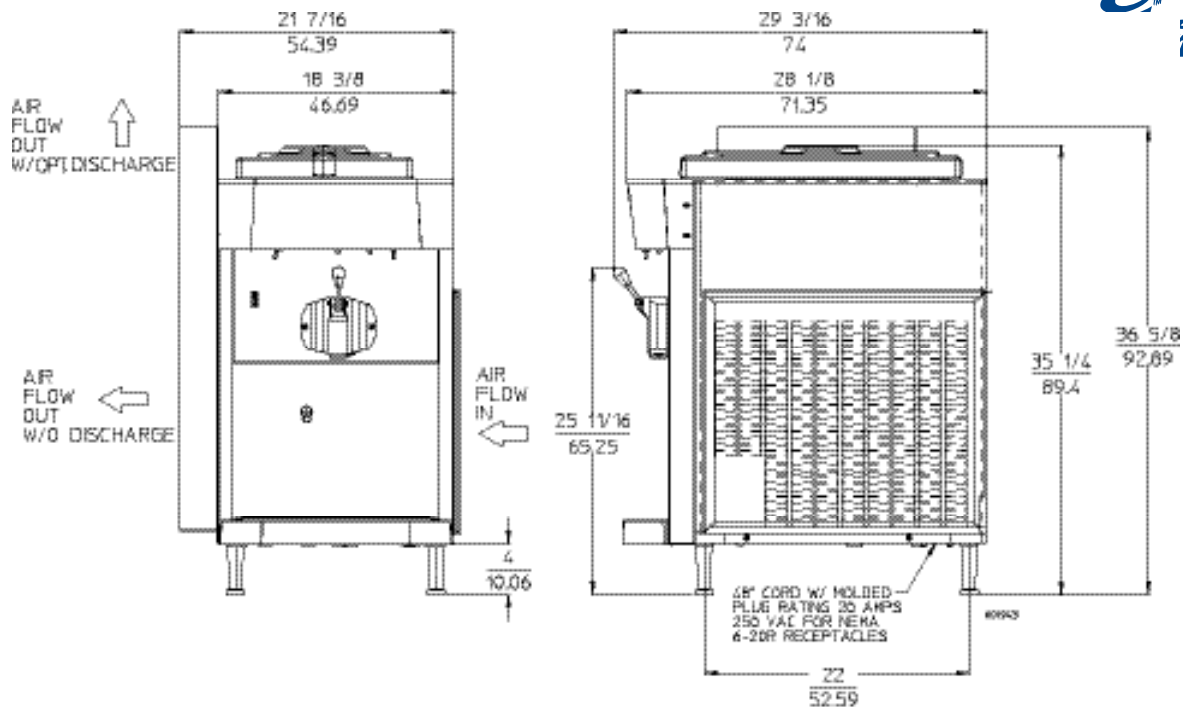

MODEL CS600 SPECIFICATIONS

Due to continual product improvements all specifications are subject to change without notice.

Weights	lbs.	kgs.
Net	294	134
Crated	390	177
	cu.ft.	cu.m.
Volume	39.5	1.2
Dimensions	in.	cm
Width	18-7/16	46.83
Depth	28-1/8	71.44
Height	35-1/4	89.56

Electrical	Maximum Fuse Size	NEMA Plug Type		
208-230/60/1 Air	20	6-20P		
208-230/60/1 Water	20	6-20P		
	Total Amps (Qty)	kW	Poles (P)	Wires (W)
220-240/50/1 Air	12	1.78	2P	2W

Electrical characteristics other than above available on request from factory or local distributor. Check nameplate for exact electrical data.

Bidding Spec

Electrical: Volt _____ Hz _____ Ph _____
 Cooling: _____ Neutral _____ Yes _____ No
 Options: _____

Electrical

One dedicated electrical connection is required. 60 Hertz units connect to a standard NEMA 6-20R receptacle. See electrical chart for the proper requirement. Consult your local electrical codes for receptacle specifications.

Beater Motor

One, 1.5 hp.

Refrigeration Systems

One, 9,500 Btuh. R404a.
 Btuh may vary depending on compressor used.

Air Cooled

3" (7.6 cm) air space required on sides and behind rear panel for proper air circulation

Mix Hopper Capacity: one - 20 quarts (18.8 liters) each
Freezing Cylinder Capacity: one - 3.7 quarts (3.5 liters) each

Certified and/or listed by:



*UL listed and listed by Underwriters Laboratories under Canadian National Standard C22.2 No. 120-13

**Selected voltages only. Contact H.C. Duke to verify agency needs.



Electro Freeze div. of H.C. Duke & Son, LLC

2116-8th Avenue, East Moline, Illinois 61244 USA
 Phone (309) 755-4553 • (800) 755-4545
 FAX (309) 755-9858
 E-mail: sales@electrofreeze.com • www.electrofreeze.com

Authorized Distributor