

THE EPITOME OF VERSATILITY.

FSPW SUPREME™

Reduce operating costs and improve flavor consistency - dispense precise, adjustable portions of heated fudge, caramel and cheese

Protects product - temperature-sensing thermostat prevents burning, and lid retains moisture



Spout heater keeps toppings inside warm and fluid

Merchandising magnets provide quick product identification

Reduce waste and speed clean-up - dispense from 48 oz pouches with the **NEW** pouched dispensing model



SUPREME™ MERCHANDISERS Model FSPW

Food Applications

- Top desserts with fudge or caramel
- Dose precise portions of cheese sauce for nachos, pretzel bits, cheese dogs, and more
- Jar accessory is perfect for operations with homemade toppings

Fast Facts

An NSF listed rethermalizer, Server's Supreme™ Hot Topping Merchandiser quickly and evenly heats toppings to a safe serving temperature without scorching product around container edges.

Portion Optimization keeps food costs low by minimizing waste and inconsistent servings while providing consistent flavors every day at each of your locations. Pumps dispense 1 oz (30 mL) max portion - reduce portions in 1/8 oz (3.7 mL) increments with gauging collars.



Additional cheese sauce and caramel magnets



1.800.558.8722
Server-Products.com

WHAT A SWEET 3-IN-1 DEAL.

SUPREME™ HOT TOPPING MERCHANDISERS

Models FSPW-SS

Specifier Statement

Unit will be Server Products Model FSPW Supreme™ Hot Topping Merchandiser or Supreme™ Pouched Product Merchandiser constructed of a stainless steel body with black thermoset plastic bottom and top. Includes (3) merchandising magnets: Caramel, Fudge and Cheese Sauce. The pouched product model features a pouch-piercing valve body and anodized aluminum pouch support to dispense from a 48 oz (1.4 L) pouch with center fitment. Pump for #10 can model dispenses from manufacturer's #10 can or Server's 3 qt (2.8 L) stainless steel jar (94009) (sold separately). Both dispense in 1 oz (30 mL) max portions adjustable in 1/8 oz (3.7 mL) increments. NSF listed. C-UL-US listed. Two-year warranty. Ships FOB Richfield, WI 53076.

Supreme™ Product Code

- Supreme™ (#10 Cans) FSPW-SS 81140
- Supreme™ (Pouches) FSPW-SS 100066

Specifications

Part Number	Capacity	Dimensions (height x width x depth)	Weight	Electrical
81140	#10 Can	15 7/16" x 8 15/16" x 16 5/8"	15 lb	120V 517W
	3 qt (2.8L) Jar		6.8 kg	
100066	48 oz (1.4 L) pouch	39.2 x 22.7 x 39.4 cm	19 lb 8.6 kg	4.3A



Plug is NEMA 5-15P with 72" (183 cm) cord

Also available for 220-240V with  plug types*

*For #10 can version only



Accessories

- Magnet Replacement Kit 86749
 - 3 qt (2.9 L) Jar* 94009
- *For #10 can version only

Related Items

Server's Supreme™ Butter Warmer dispenses the perfect amount of heated butter for any application; precise temperatures keep butter from scorching or burning. Portion control keeps flavors consistent and controls cost; portions are adjustable in 1/8 oz increments with a 1 oz maximum portion.

Server's SlimLine™ Dry Food Dispensers display and dispense preset portions of up to (4) candies, toppings, or mix-ins in less than 13" of wall space. Control costs with precise portions; color-coded trays identify serving size. Stands are available for countertop dispensing.



Supreme™ Butter Warmer



SlimLine™

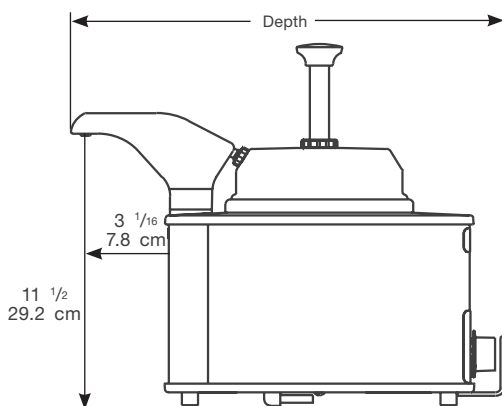
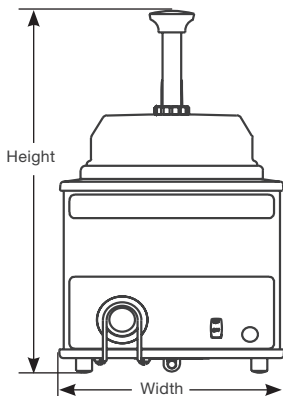

Server Products, Inc. 800.558.8722 | Intl: 262.628.5600
 3601 Pleasant Hill Road | Richfield WI 53076
 spsales@server-products.com | server-products.com

Server Products, Inc. reserves the right to modify specifications without obligation.
 Printed in USA | © Server Products, Inc 06.2019 | S.02012