



K 3/E

M

High volume unit for combined production of shakes and sundaes. It features two independent, high-volume freezers in one compact structure. If needed, one side can be stopped while the other side remains in full operation.



Performance The Carpigiani Hard-O-Tronic consistency control constantly checks the viscosity of the product. It manages the refrigeration system to deliver to your customer the best quality shake & ice-cream product available. Production Capacity: 84 lbs. of ice cream and 88 lbs (68 qts) of shake.



Convenience Carpigiani's smart technology stores each and every machine event and can be recalled during diagnostic, statistic and operational review. State-of-the-art control pad informs the operator during every machine function while also providing critical diagnostic information.



Savings Carpigiani patented mix pumps guarantees consistent over-run and maximizes restaurant profitability. Carpigiani's unique electrical technology maximizes efficiency while helping to reduce restaurant energy costs.



Safety Optional TEOREMA provides remote tracking of servings, cleanings and alerting of service requirements to both service team and operator.



Hygiene The peristaltic pump delivery system optimizes restaurants TTS syrup use with or without fruit particulates. The syrup valves are easily removable for sanitizing.



*Carpi Care kit: request it from your dealer to always keep your machine hygienically perfect.

carpigiani.com/us

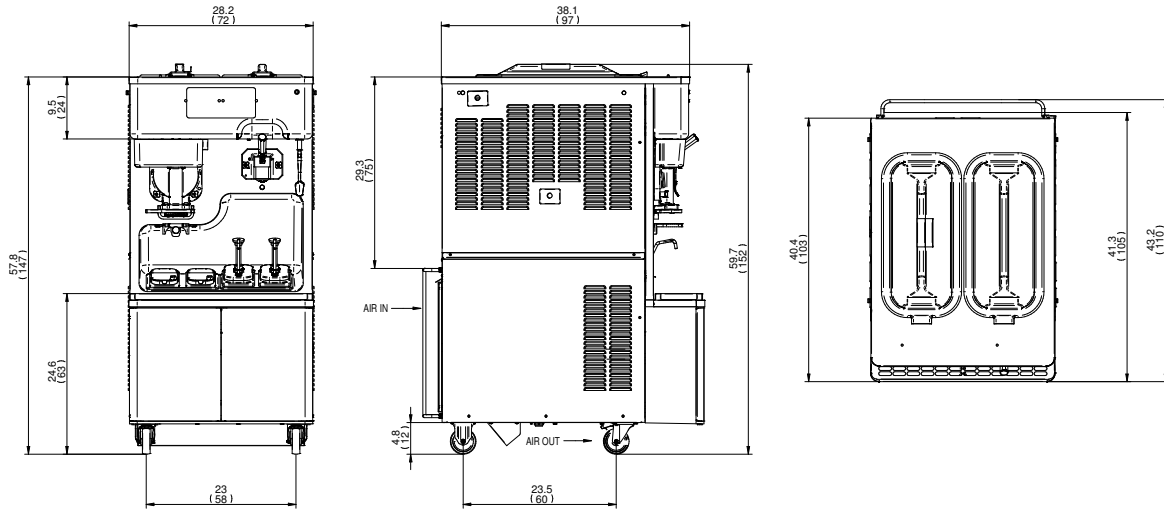

AIR

Weights	lbs.	kgs.	
Net	881	400	
Crated	1062	482	
Volume	cu. ft.	cu. m.	
Volume	69.57	1.97	
Dimensions	in.	cm.	
Width	28.2	72	
Depth	43.2	110	
Height	57.8	147	
Electrical	Maximum Fuse Size	Minimum Circuit Ampacity	Poles (P) Wires (W)
208-230/60/3 Air	30A	28A	3P, 3W

Specifications

Electrical

A dedicated electrical connection is required. Manufactured to be permanently connected. See the Electrical chart for the proper electrical requirements. Consult your local Carpigiani distributor for cord & receptacle specifications as local codes allow.

Beater Motor

shake side 1 HP - soft side 1,5 HP

Refrigeration System

R404A

Air Cooled *

Minimum clearance: 0" (0 cm) on both side panels and 2" (5 cm) from the rear panel for proper air circulation.

Cylinder Capacity

21 quarts (19,9 liters)

All specifications mentioned must be considered approximate; Carpigiani reserves the right to modify, without notice, all parts deemed necessary. This unit may be manufactured in other electrical characteristics and may have additional regulatory agency approvals, please consult the local Carpigiani Distributor. Check name plate for exact electrical data. * Room temperature 68°F (20°C).

Bidding Specs

Electrical Volt _____ Hz _____ Ph _____ Neutral Yes No Cooling Air Water

Options _____



738 Gallimore Dairy Road, Suite 113
High Point, NC - 27265
Toll free (800) 648 4389

Dealer



carpigiani.com/us

an Ali Group Company



The Spirit of Excellence