



Pastochef

18 RTL

Create pastry, chocolate, savory specialties and frozen dessert mixtures.



Performance Mix, heat, cook, cool, age & store your pastry creations in the Pastochef. Perfect for classic pastry creams as well as providing the tools and freedom for creative recipes for the Pastry Chef and Chocolatier. Create recipes of everything from Ganache Cream, Bechamel sauce, fruit jams and even savory dishes such as Polenta & Ragu Bolognese! Pastochef includes 45 automatic programs (temperatures can be modified) & 5 personalized programs.



Convenience Easily prepare recipes that are traditionally labor-intensive- without reducing quality. Spigot accommodates liquid and very thick products. Includes full recipe book with minimum and maximum amounts for each recipe.



Safety Safety closure to protect liquid ingredients. Protective cover to avoid splashes.



Hygiene Pastochef will guarantee product safety even during power or water outage by either completing cycle if possible or going into storage mode. Built-in faucet with flex hose makes cleaning fast and easy.



*Carpigiani Care kit: request it from your dealer to always keep your machine hygienically perfect.

carpigiani.com/us

Pastochef 18 RTL

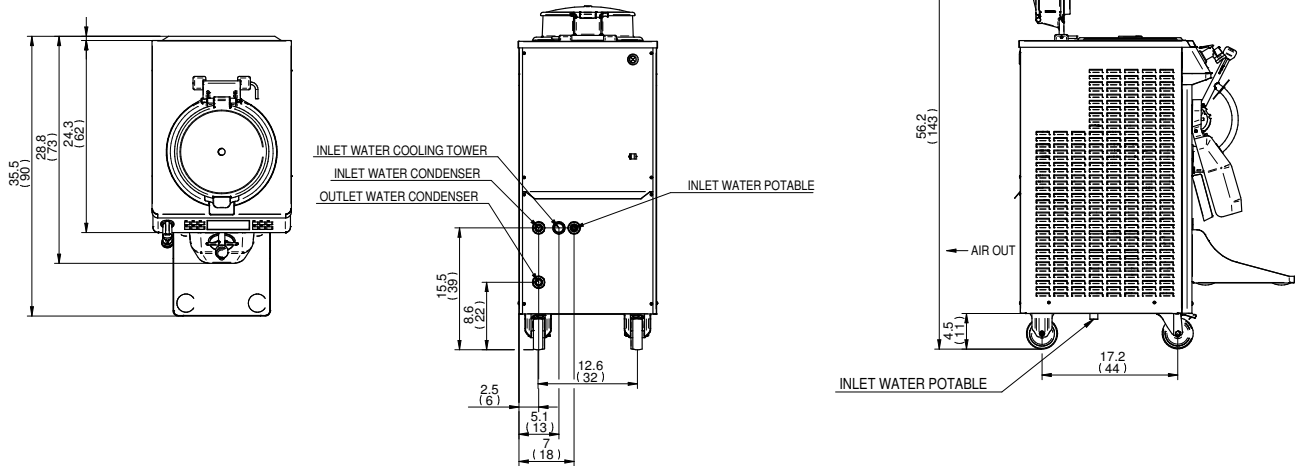

	WATER		AIR	
Weights	lbs.	kgs.	lbs.	kgs.
Net	330	150	330	150
Crated	363	165	363	165
	cu. ft.	cu. m.	cu. ft.	cu. m.
Volume	24.7	0.7	24.7	0.7
Dimensions	in.	cm.	in.	cm.
Width	17.72	45	17.72	45
Depth	36.9	94	35.43	90
Height	43.7	111	43.7	111
Electrical	Maximum Fuse Size	Minimum Circuit Ampacity	Poles (P) Wires (W)	
208-230/60/3 Water	15A	12A	3P, 3W	
208-230/60/3 Air	15A	12A	3P, 3W	

Specifications

Electrical

A dedicated electrical connection is reqs. Manufactured to be permanently connected. See the Electrical chart for the proper electrical requirements. Consult your local Carpigiani distributor for cord & receptacle specifications as local codes allow.

Beater Motor

0,4/0,3 HP

Refrigeration System

R134A

Water Cooled

Water inlets and drain connections in the rear 1/2" MPT

Air Cooled *

Minimum clearance: 6" (15 cm) on both side panels and 24" (60 cm) from the rear panel for proper air circulation.

Tank Capacity

16 quarts (15 liters)

All specifications mentioned must be considered approximate; Carpigiani reserves the right to modify, without notice, all parts deemed necessary. This unit may be manufactured in other electrical characteristics and may have additional regulatory agency approvals, please consult the local Carpigiani Distributor. Check name plate for exact electrical data. * Room temperature 68°F (20°C).

Bidding Specs

Electrical Volt _____ Hz _____ Ph _____ Neutral Yes No Cooling Air Water

Options _____



738 Gallimore Dairy Road, Suite 113
High Point, NC - 27265
Toll free (800) 648 4389

Dealer



carpigiani.com/us

an Ali Group Company



The Spirit of Excellence