



# Pastomaster

## 120 RTX

The classic Carpigiani heat treatment equipment. Prepare base mixtures for Ice Cream, Gelato & Custard as well as prepare create gourmet specialties & syrups like pudding, chocolate syrup & more



**Performance** The 120 RTX is the perfect large mix treatment solution for major gelaterie and large frozen dessert wholesale operations, that furnish multiple points-of-sale. It features low homogenization\*, 7 mix treatment programs, and a refrigerated extraction spigot. It is capable of mixing up to 120 liters (32 gallons) of mix per cycle. 16 programs for base mixtures and syrups and other liquid pastry products. 6 Frozen Dessert mixture programs. 3 Syrup Programs: Chocolate, Fruit & Zabaione. 5 Gourmet programs: Invert Sugar, Cream Syrup, Pudding, Panna Cotta & Bavarian Cream. 2 Yogurt programs: Liquid Yogurt, Thick Yogurt. 9 Personalized Programs.



**Convenience** Simple easy to read control panel. Transparent lid can be opened during production process since pump is located below.



**Savings** Prepare your own base mixtures and syrups from your choice of ingredients.



**Safety** Internal temperature is shown on screen. Exchange Pump uniformly heats or cools mixture for homogenization without burning any of the mixture. Memory retention during temporary power blackout. Ergonomic design includes rounded corners to avoid injury. Optional stainless-steel drip tray is available.



**Hygiene** Built-in faucet with flex hose makes cleaning fast and easy. Optional Transfer mix set is available, ideal for transferring mixture equipment quickly and sanitarly with tube.



\*Carpi Care kit: request it from your dealer to always keep your machine hygienically perfect.

[carpigiani.com/us](http://carpigiani.com/us)

# Pastomaster 120 RTX

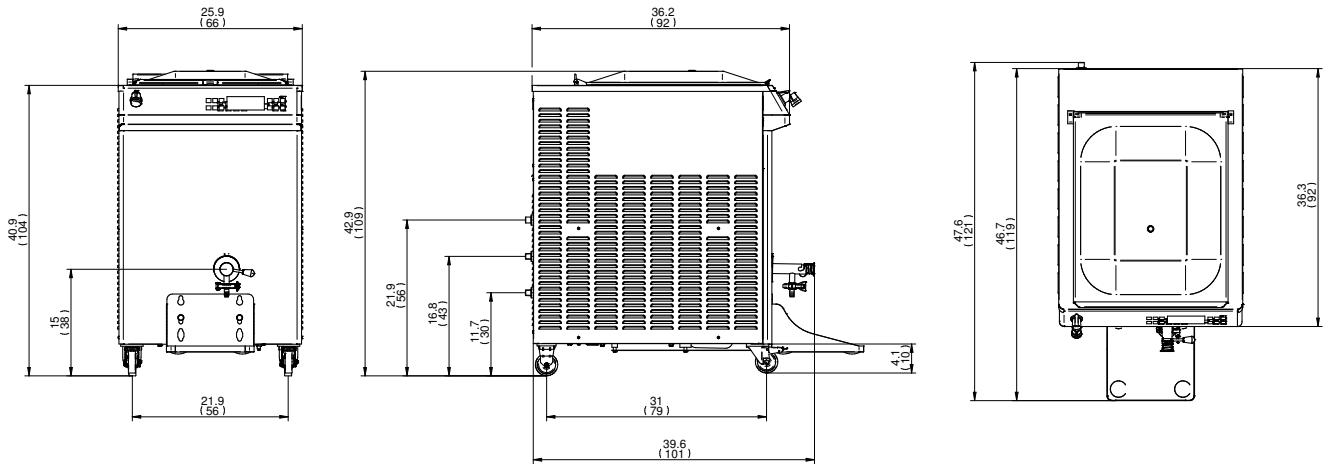

## WATER

Weights	lbs.	kgs.	
Net	595	270	
Crated	650	295	
Volume	cu. ft.	cu. m.	
Volume	34.97	0.99	
Dimensions	in.	cm.	
Width	25.9	66	
Depth	47.6	121	
Height	42.9	109	
Electrical	Maximum Fuse Size	Minimum Circuit Ampacity	Poles (P) Wires (W)
208-230/60/3 Water	70A	40A	3P, 3W

## Specifications

### Electrical

A dedicated electrical connection is required. Manufactured to be permanently connected. See the Electrical chart for the proper electrical requirements. Consult your local Carpigiani distributor for cord & receptacle specifications as local codes allow.

### Refrigeration System

R404A

### Water Cooled

Water inlets and drain connections in the rear 1/2" MPT

### Tank Capacity

32 quarts (30,28 liters)

All specifications mentioned must be considered approximate; Carpigiani reserves the right to modify, without notice, all parts deemed necessary. This unit may be manufactured in other electrical characteristics and may have additional regulatory agency approvals, please consult the local Carpigiani Distributor. Check name plate for exact electrical data.

## Bidding Specs

Electrical Volt \_\_\_\_\_ Hz \_\_\_\_\_ Ph \_\_\_\_\_ Neutral  Yes  No Cooling  Air  Water

Options \_\_\_\_\_



738 Gallimore Dairy Road, Suite 113  
High Point, NC - 27265  
Toll free (800) 648 4389

Dealer



[carpigiani.com/us](http://carpigiani.com/us)

an Ali Group Company



The Spirit of Excellence