

Metro ST

H 117 • 135

P 80

L 100 • 130

Pastry • Chocolate • Heated snack • Food & Beverage

Installation

Plug-in

Configuration

- Glass shelves 2 (H117)
- Glass shelves 3 (H135)

Temperature

- -1/+5 °C (TN)
- +14/+16 °C (CH)
- +65 °C (TCS)

Refrigerant

R290

Refrigeration

Ventilated

Compressor

Hermetic

Defrost

Off cycle (TN-CH)

Climate class

3

Front glass

Double

Side glasses

Double

Rear closing system

Glass sliding doors

Opening system

Openable glass structure towards the bottom

Lighting

- 3000 K
- 4000 K (Optional)
- 5700 K (Optional)

Equipment handling

- Height adjustable feet
- Swivel casters with brake (Optional)

Color

White RAL 9003

Installazione

Plug-in

Configurazione

- Ripiani in vetro 2 (H117)
- Ripiani in vetro 3 (H135)

Temperatura

- -1/+5 °C (TN)
- +14/+16 °C (CH)
- +65 °C (TCS)

Refrigerante

R290

Refrigerazione

Ventilata (TN-CH)

Compressore

Ermetico

Sbrinamento

Fermata compressore (TN-CH)

Classe Climatica

3

Vetro frontale

Doppio (Camera)

Vetri laterali

Doppio (Camera)

Chiusura posteriore

Scorrevoli in vetro

Apertura anteriore

Apertura ribaltabile verso il basso

Illuminazione

- 3000 K
- 4000 K (Optional)
- 5700 K (Optional)

Movimentazione

- Piedini regolabili in altezza
- Ruote pivotanti con freno (Optional)

Colore

Bianco RAL 9003



R290

METRO

Metro ST

100			130		
RV TN	RV CH	TCS	RV TN	RV CH	TCS

External dimensions (LxDxH) Dimensioni esterne (LxPxH)	H117 H135	1000x833x1170/1216 mm 1000x833x1350/1397 mm			1300x833x1170/1216 mm 1300x833x1350/1397 mm	
Capacity (gross/net) Capacità (lorda/netta)	H117 H135	523,5 / 237,8 lt 652 / 305,6 lt			687 / 312,1 lt 855,5 / 401,2 lt	
Net weight Peso netto	H117 H135	200 kg 210 kg	175 kg 185 kg	205 kg 215 kg	180 kg 190 kg	
Refrigeration Refrigerazione		Ventilated Ventilata			Ventilated Ventilata	
Refrigerant Refrigerante		R290			R290	
Climate class Classe climatica		3				
Operating conditions Condizioni ambientali		25 °C / 60 %RH				
Product temperature Temperatura prodotto		-1/+5 °C	+14/+16 °C	+65 °C	-1/+5 °C	+14/+16 °C +65 °C
Compressor (q.ty - type) Compressore (q.tà - tipologia)		1 - Hermetic 1 - Ermetico			1 - Hermetic 1 - Ermetico	
Defrost Sbrinamento		Off Cycle Fermata compressore			Off Cycle Fermata compressore	
Power supply Alimentazione		230 V / 1 Ph / 50 Hz				
Electrical input (nominal) Assorbimento elettrico (regime)		530 W / 3,1 A	750 W / 4,2 A	800 W / 3,5 A	550 W / 3,1 A	770 W / 4,3 A 930 W / 4,2 A
Electrical input (defrost) Assorbimento elettrico (sbrinamento)		35 W / 0,2 A			35 W / 0,2 A	

Technical sheet about models whit condensing unit included with air cooled
Dati tecnici riferiti a modelli con unità a bordo con condensazione ad aria

Setup

Allestimento

Shelf (LxD) Ripiano (LxP)	907 x 400 mm	1207 x 400 mm
Bottom shelf (LxD) Ripiano di fondo (LxP)	910 x 602 mm	1210 x 602 mm

H 117 | RV TN | RV CH

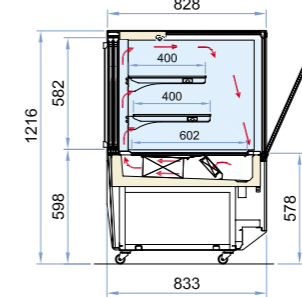
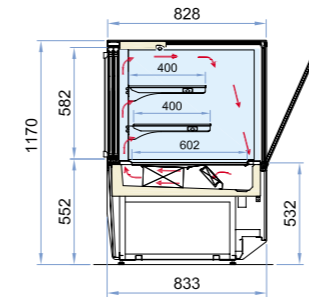

TCS

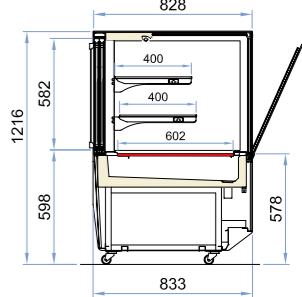
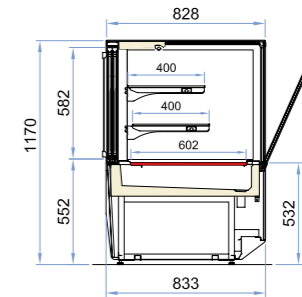

H 135 | RV TN | RV CH

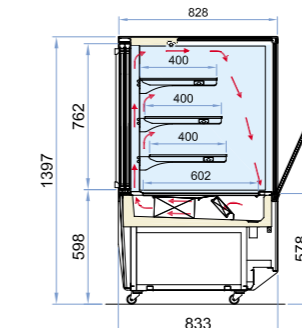
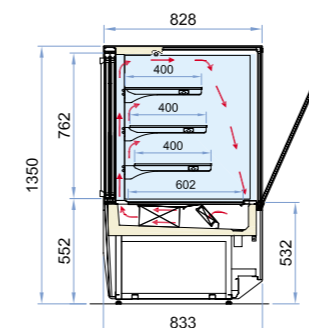

TCS

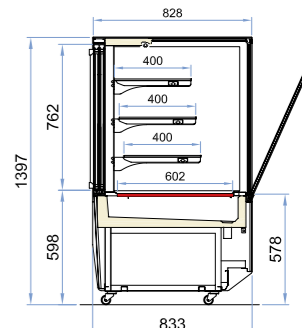
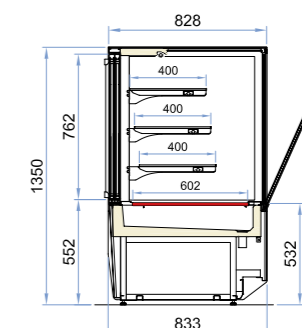

Metro ST Self

H 117 • 135
P 80
L 100 • 130

Food & Beverage

Installation

Plug-in

Configuration

- Glass shelves 2 (H117)
- Glass shelves 3 (H135)

Temperature

-1/+7 °C (TN)

Refrigerant

R290

Refrigeration

Ventilated

Compressor

Hermetic

Defrost

Off cycle (TN)

Climate class

3

Side glasses

Double

Rear closing system

Glass sliding doors

Front closing system

Self rolling curtain

Lighting

- 3000 K
- 4000 K (Optional)
- 5700 K (Optional)

Equipment handling

- Height adjustable feet
- Swivel casters with brake (Optional)

Color

White RAL 9003

Installazione

Plug-in

Configurazione

- Ripiani in vetro 2 (H117)
- Ripiani in vetro 3 (H135)

Temperatura

-1/+7 °C (TN)

Refrigerante

R290

Refrigerazione

Ventilata (TN)

Compressore

Ermetico

Sbrinamento

Fermata compressore (TN)

Classe Climatica

3

Vetri laterali

Doppio (Camera)

Chiusura posteriore

Scorrevoli in vetro

Chiusura anteriore

Tendina manuale autoavvolgente

Illuminazione

- 3000 K
- 4000 K (Optional)
- 5700 K (Optional)

Movimentazione

- Piedini regolabili in altezza
- Ruote pivotanti con freno (Optional)

Colore

Bianco RAL 9003

METRO

Metro ST Self

		100	130
		RV TN	RV TN
External dimensions (LxDxH)	H117	1000x833x1170/1216 mm	1300x833x1170/1216 mm
Dimensioni esterne (LxPxH)	H135	1000x833x1350/1397 mm	1300x833x1350/1397 mm
Capacity (gross/net)	H117	105,8 / 410 lt	258,1 / 538 lt
Capacità (lorda/netta)	H135	264,6 / 501,1 lt	347,2 / 658 lt
Net weight	H117	200 kg	205 kg
Peso netto	H135	210 kg	215 kg
Refrigeration	Ventilated		
Refrigerazione	Ventilata		
Refrigerant	R290		
Refrigerante			
Climate class	3		
Classe climatica			
Operating conditions	25 °C / 60 %RH		
Condizioni ambientali			
Product temperature	-1/+7 °C		
Temperatura prodotto			
Compressor (q.ty - type)	1 - Hermetic		
Compressore (q.tà - tipologia)	1 - Ermetico		
Defrost	Off Cycle		
Sbrinamento	Fermata compressore		
Power supply	230 V / 1 Ph / 50 Hz		
Alimentazione			
Electrical input (nominal)	850 W / 3,9 A		910 W / 4,1 A
Assorbimento elettrico (regime)			
Electrical input (defrost)	60 W / 0,3 A		
Assorbimento elettrico (sbrinamento)			

Technical sheet about models with condensing unit included with air cooled
Dati tecnici riferiti a modelli con unità a bordo con condensazione ad aria

Setup

Allestimento

Shelf (LxD)	907 x 260 mm	1207 x 260 mm
Ripiano (LxP)	907 x 350 mm	1207 x 350 mm
	907 x 400 mm	1207 x 400 mm
Bottom shelf (LxD)	910 x 602 mm	1210 x 602 mm
Ripiano di fondo (LxP)		



R290



H 117 | RV TN

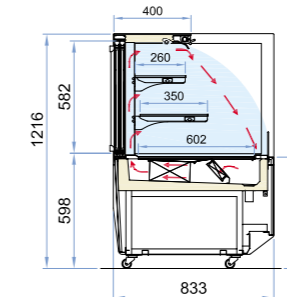
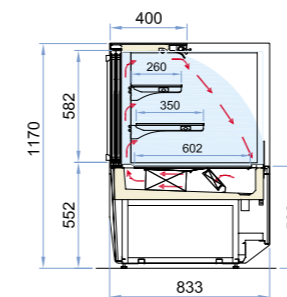

H 135 | RV TN

