





# SUPERSHOW

Gelato and pastry display cabinet



## Gelato, star of its own show.

Supershow is the result of a harmonious combination of surfaces, materials and transparencies that revolutionize the standards of artisanal ice cream display. The narrow steel side supports give a panoramic view of the product. The holders for the transparent ice cream tubs and the top to bottom LED lighting system make the ice cream appear to float inside the display case.





Excellent gelato visibility.

Eccellente visibilità del gelato.

IT

### Il gelato protagonista nello spettacolo del gusto

Supershow nasce da una combinazione armonica di superfici, materiali e trasparenze che rivoluziona i paradigmi dell'esposizione del gelato artigianale. I montanti laterali in acciaio a ridotto spessore agevolano una visione panoramica del prodotto. I supporti per le vaschette trasparenti ed il sistema di illuminazione combinata full-led dall'alto e dal basso fanno apparire il gelato sospeso all'interno della vetrina.

FR

### La glace protagoniste du spectacle du goût.

Supershow nait d'une combinaison harmonieuse de surfaces, de matériaux et de transparences qui révolutionne les modèles de présentation de la glace artisanale. Les montants latéraux en acier à l'épaisseur réduit facilitent la vue panoramique du produit. Les supports pour le bacs transparents et le système d'éclairage combiné full-led d'en haut et d'en bas font sembler la glace suspendue à l'intérieur de la vitrine.

DE

### Das Eis ist der Protagonist In der Vorstellung des Geschmackes.

Supershow ergibt sich aus einer harmonische Kombination von Oberflächen, Materialien und Transparenz, welche das Paradigma der Exposition des Handwerkseises revolutioniert. Die seitlichen Stahlstützen, die eine reduzierte Dicke haben, ermöglichen einen Überblick über dem Produkt. Die Halterungen für die transparenten Schalen und die kombinierte full-LED Beleuchtungsanlage von oben und unten darstellen das wie in der Luft schwebenden Eis im inneren des Gehäuses.

ES

### El helado como protagonista en el espectáculo del sabor.

Supershow nace de una combinación armónica de superficies, materiales y transparencias que revolucionan los prototipos de exposición del helado artesanal. Los laterales de acero de espesor reducido facilitan una visión panorámica del producto. Los soportes de los recipientes transparentes y el sistema de iluminación con tecnología full LED en la parte superior e inferior del expositor muestran el helado suspendido en el interior de la vitrina. ahorro energético.



SUPERSHOW

## A spectacular view from every angle

Supershow is the ideal format to maximize the display appeal of artisanal ice cream. It enhances the three-dimensional display of the product and provides an impressive view from every angle thanks to the front and sides of the display case, together with the ice cream tubs, all being completely transparent.





IT

### Una vista spettacolare da ogni punto di vista.

Supershow è il palcoscenico ideale per esaltare al massimo il food appeal del gelato artigianale, valorizzare al meglio la tridimensionalità del prodotto e regalare una vista mozzafiato da ogni punto di vista grazie ai fianchi, al frontale della vasca refrigerata e alle vaschette gelato completamente trasparenti.

DE

### Eine spektakuläre Aussicht von jedem Standpunkt.

Supershow ist die ideale Bühne um die Anziehungskraft des Eises eigener Herstellung hervorzuheben, den dreidimensionalen Charakter am Besten zur Geltung zu bringen. Und einen atemberaubenden Blick von jedem Standpunkt geben, dank zu den Seiten, dem Frontglass und die komplett durchsichtigen Packungen.

FR

### Une vue extraordinaire de chaque point de vue.

Supershow c'est la scène idéale pour exalter au maximum le food appeal de la glace artisanale, mettre en valeur au mieux la tridimensionnalité du produit et offrir une vue excellente de chaque point de vue grâce aux côtés, au vitre frontale du bac réfrigérant et aux bacs complètement transparents.

ES

### Una visión espectacular desde todos los puntos de vista.

Supershow es el escenario ideal para ensalzar el "food appeal" del helado artesanal, apreciar mejor la tridimensionalidad del producto y ofrecer una visión arrebatadora desde todos los ángulos gracias a los laterales, al frontal del expositor y a los recipientes de helado completamente transparentes.





## 2030 Phase-out F-GAS

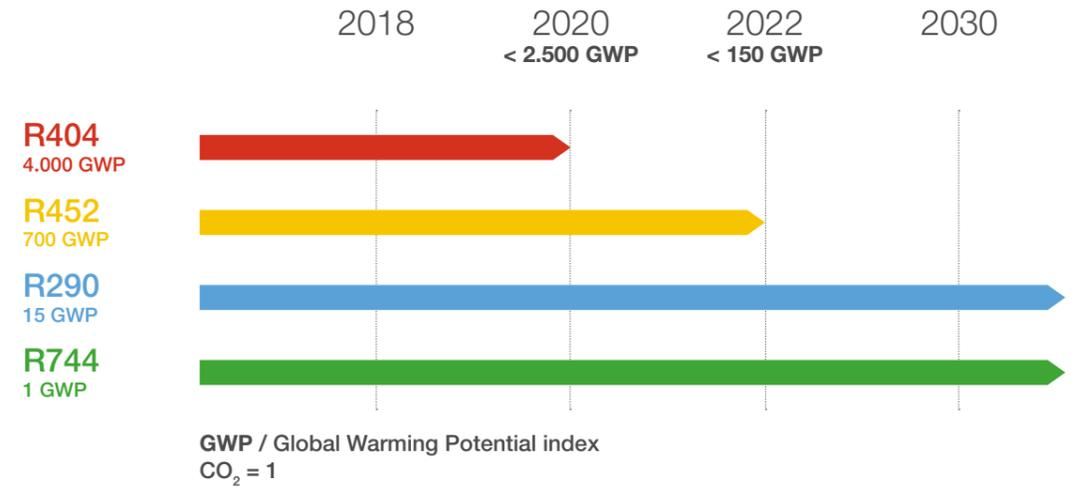

### EUROPEAN REGULATION F-GAS 517/2014

## The future is in the air

For ISA, sustainability is not only confined to the product but encompasses a great deal more: it is also a production process and is, above all, respect for the person and the environment. You too can help make a difference, by choosing ARIA and becoming an ambassador for a new model of development. With the simplicity and the constancy of daily actions. From today, thanks to ISA research and development, there is now eco-friendly products that use natural refrigerant not only as an expanding agent in insulating foams but also as a refrigerant in the fridge system.

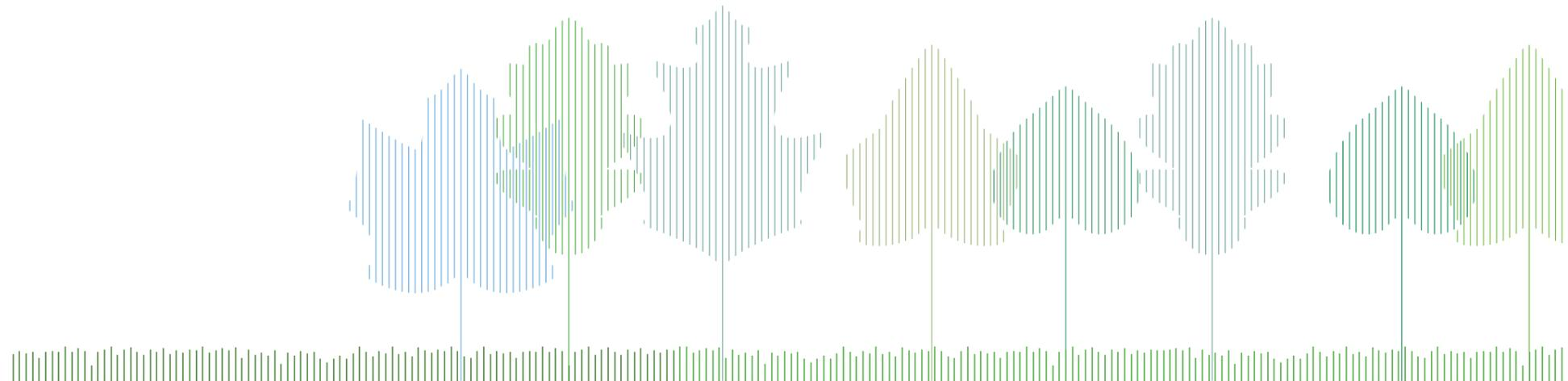

IT

Per ISA la sostenibilità non si limita al solo prodotto, ma è molto di più: è anche processo produttivo e soprattutto è rispetto della persona e dell'ambiente. Anche tu puoi contribuire a fare la differenza, scegliendo "ARIA" e diventando ambasciatore di un nuovo modello di sviluppo. Con la semplicità e la costanza dei gesti quotidiani. Da oggi grazie alla ricerca e sviluppo ISA è possibile avere una gamma di prodotti ecosostenibili che utilizzano i refrigeranti naturali non solo come agente espandente nelle schiume isolanti ma anche come refrigerante nell'impianto frigo.

FR

Pour Isa, la durabilité ne se limite pas uniquement au produit, c'est beaucoup plus: c'est aussi un procédé de production et c'est surtout le respect de la personne et de l'environnement. Vous êtes en mesure de contribuer à faire la différence, en choisissant ARIA et en devenant l'ambassadeur d'un nouveau modèle de développement. Avec la simplicité et la constance des gestes quotidiens. Grâce à la recherche et au développement d'ISA, il est aujourd'hui possible d'avoir une gamme de produits encore plus respectueux de l'environnement, qui utilisent le réfrigérant naturel CO<sub>2</sub> non seulement comme agent d'expansion des mousses isolantes mais aussi comme réfrigérant du réfrigérateur.

DE

Für Isa beschränkt sich die Nachhaltigkeit nicht nur auf das Produkt, sie umfasst weit mehr: Sie ist auch der Herstellungsprozess und vor allem schützt sie die Personen und die Umwelt. Auch Sie können den Unterschied machen, indem Sie sich für ARIA entscheiden und Botschafter eines neuen Entwicklungsmodells werden. Mit der Schlichtheit und Beständigkeit der alltäglichen Gesten. Seit heute ist es dank der Isa Forschung und Entwicklung möglich, unter einer noch umweltfreundlicheren Bandbreite von Produkten auszuwählen, die das natürliche Kältemittel CO<sub>2</sub> nicht nur als Schäummittel im Isolierschaum sondern auch als Kühlmittel in Kühlgeräten verwenden.

ES

Para Isa, la sostenibilidad no se limita únicamente al producto, sino que es algo más: también es proceso de producción y, sobre todo, respeto por la persona y el medio ambiente. También Tú puedes contribuir a marcar la diferencia, eligiendo ARIA y convirtiéndote en embajador de un nuevo modelo de desarrollo, con la simplicidad y constancia de los gestos cotidianos. Desde hoy, gracias a la investigación y al desarrollo de Isa, es posible tener una gama de productos mucho más sostenibles ecológicamente que utilizan el refrigerante natural CO<sub>2</sub> no sólo como agente expansor en las espumas aislantes sino también como refrigerante en la instalación frigorífica.



# Gelato

# SUPERSHOW

H 117 • 135

P 110

L 120 • 155 • 170 • 190 • 220 • AE45

## Gelato

### Installation

- Plug-in
- Remote (optional)

### Configuration

- Canalized (optional)
- Dual Temperature (optional)

### Temperature

-20/+2 °C

### Refrigerant

R404A  
R744 (on request)

### Refrigeration

Ventilated

### Compressor

Semi-Hermetic

### Defrost

Reverse cycle

### Climate class

4

### Upper glass

Heated stratified  
with switch

### Front glass

Heated stratified

### Side glasses

Heated double

### Opening system

Openable glass structure  
towards the bottom

### Rear closing system

Plexiglass Sliding doors

### Work top

- Solid surface White
- Fenix Black

### Lightning

Led 5700 K°

### Equipment handling

Swivel casters with brake  
and height adjustable feet

### Installazione

- Plug-in
- Remoto (optional)

### Configurazione

- Canalizzabile (optional)
- Dual Temperature (optional)

### Temperatura

-20/+2 °C

### Refrigerante

R404A  
R744 (su richiesta)

### Refrigerazione

Ventilata

### Compressore

Semi-Ermetico

### Sbrinamento

Inversione di ciclo

### Classe Climatica

4

### Vetro superiore

Stratificato riscaldato  
(disattivabile)

### Vetro frontale

Stratificato riscaldato

### Vetri laterali

Doppio (camera) riscaldato

### Apertura anteriore

Apertura ribaltabile  
verso il basso

### Chiusura posteriore

Scorrevoli in Plexiglass

### Piano di servizio

- Superficie solida bianca
- Fenix Nero

### Illuminazione

Led 5700 K°

### Movimentazione

Ruote pivotanti con freno  
e piedini regolabili in altezza



**Front glass**  
Heated stratified

**Vetro frontale**  
Stratificato riscaldato

**Upper glass**  
Heated stratified  
with switch

**Vetro superiore**  
Stratificato riscaldato  
(disattivabile)

**Side glasses**  
Heated double

**Vetri laterali**  
Doppi (Camera) riscaldati

### Dual Temperature

Designed with maximum flexibility to allow seasonal product display management. The Dual Temperature function (optional) allows the display cabinet to change simply, the operating temperature for Ice Cream and Pastry Products. This allows one cabinet to offer seasonal flexibility without increasing floor space.

Massima flessibilità e perfetta gestione dei cicli stagionali. La funzione Dual Temperature (optional) permette alla vetrina di passare con estrema semplicità da Gelateria a Pasticceria, e viceversa, permettendovi di avere un locale multifunzionale con un unico prodotto: possibilità di variare stagionalmente l'offerta e il layout del vostro spazio.

		120	155	170
<b>External dimensions (LxDxH)</b>	H117	1187 x 1105 x 1170 mm	1517 x 1105 x 1170 mm	1682 x 1105 x 1170 mm
Dimensioni esterne (LxPxH)	H135	1187 x 1105 x 1350 mm	1517 x 1105 x 1350 mm	1682 x 1105 x 1350 mm
<b>Capacity (gross/net)</b>	H117	685 / 147 lt	901 / 193 lt	1009 / 216 lt
Capacità (lorda/netta)	H135	824 / 147 lt	1083 / 193 lt	1212 / 216 lt
<b>Net weight</b>	H117	320 kg	368 kg	409 kg
Peso netto	H135	331 kg	382 kg	419 kg
<b>Refrigeration</b>		<b>Ventilated</b>		
Refrigerazione		Ventilata		
<b>Refrigerant</b>		R404A		
Refrigerante				
<b>Climate class</b>		4		
Classe climatica				
<b>Operating conditions</b>		30 °C / 55 %RH		
Condizioni ambientali				
<b>Cabinet capacity range</b>		-20/+2 °C		
Temperatura di regolazione				
<b>Product temperature</b>		-16/-14 °C		
Temperatura prodotto				
<b>Compressor (type)</b>		<b>1 Semi-Hermetic</b>		
Compressore (tipologia)		1 Semi-Ermetico		
<b>Defrost</b>		<b>Reverse Cycle</b>		
Sbrinamento		Inversione di Ciclo		
<b>Power supply</b>		400 V / 3 Ph / 50 Hz		
Alimentazione				
<b>Electrical input (nominal)</b>		1740 W / 3,1 A	2470 W / 6,3 A	2780 W / 6,8 A
Assorbimento elettrico (regime)				
<b>Electrical input (defrost)</b>		3260 W / 7,9 A	3870 W / 8,5 A	4250 W / 9,6 A
Assorbimento elettrico (sbrinamento)				

Technical sheet about models whit condensing unit included with air cooled  
Dati tecnici riferiti a modelli con unità a bordo con condensazione ad aria

#### Setup Allestimento

<b>5 Lt</b> 360 x 165 x 120 h		12	16	18
<b>5 Lt</b> 360 x 250 x 80 h		8	10	12
<b>5 Lt (trapezoidali)</b> 360 x 185 x 120 h		-	-	-
<b>Ice cream stick container</b> Stecchi vaschetta		•	•	•
<b>Single portions container</b> Monoporzioni		•	•	•
<b>Pastry Tray</b> Vassoi pasticceria		•	•	•

#### Available colours - Colori disponibili

Front panel (1) Pannello frontale	Front grid (2) Griglia frontale	Side panels (3) Fianchi laterali
•  RAL on demand	•  RAL 9005	•  RAL on demand
• Standard / Di serie	• Standard / Di serie	• Standard / Di serie



	190	220	AE45
1847 x 1105 x 1170 mm	1847 x 1105 x 1170 mm	2177 x 1105 x 1170 mm	1847 x 1105 x 1170 mm
1847 x 1105 x 1350 mm	1847 x 1105 x 1350 mm	2177 x 1105 x 1350 mm	1847 x 1105 x 1350 mm
1116 / 239 lt	1332 / 285 lt	1332 / 285 lt	901 / 193 lt
1341 / 239 lt	1600 / 285 lt	1600 / 285 lt	1082 / 193 lt
459 kg	510 kg	510 kg	400 kg
468 kg	520 kg	520 kg	410 kg
	<b>Ventilated</b>		
	Ventilata		
	R404A		
	4		
	30 °C / 55 %RH		
	-20/+2 °C		
	-16/-14 °C		
	<b>1 Semi-Hermetic</b>		
	1 Semi-Ermetico		
	<b>Reverse Cycle</b>		
	Inversione di Ciclo		
	400 V / 3 Ph / 50 Hz		
3600 W / 9,7 A	3950 W / 9,9 A	3950 W / 9,9 A	2300 W / 5,5 A
4600 W / 10,8 A	5040 W / 11,4 A	5040 W / 11,4 A	3600 W / 8,5 A

20	24	13
12	16	9
-	-	14
•	•	9
•	•	9
•	•	•

#### H117

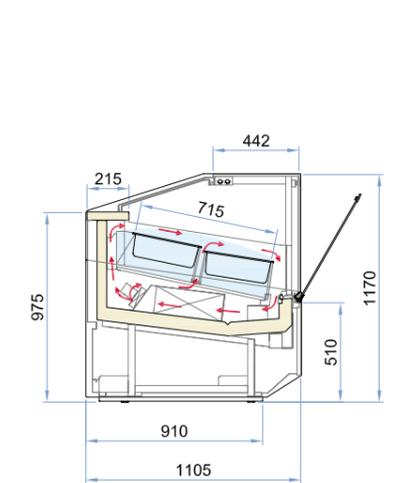

#### H135

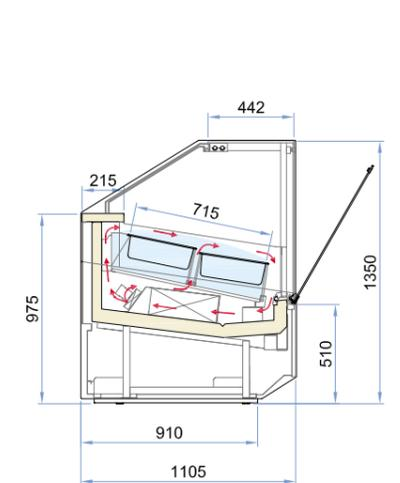



# Pastry

# SUPERSHOW

H 117 • 135

P 110

L 120 • 170 • 220 • AE45

## Pastry

### Installation

- Plug-in
- Remote (optional)

### Configuration

Canalized (optional)

### Temperature

+1/+10 °C

### Refrigerant

R404A

### Refrigeration

Ventilated

### Compressor

Hermetic

### Defrost

Off cycle

### Climate class

3

### Upper glass

Heated stratified with switch

### Front glass

Heated stratified

### Side glasses

Heated double

### Opening system

Openable glass structure towards the bottom

### Rear closing system

Plexiglass Sliding doors

### Work top

- Solid surface White
- Fenix Black

### Lightning

Led 5700 K°

### Equipment handling

Swivel casters with brake and height adjustable feet

### Installazione

- Plug-in
- Remoto (optional)

### Configurazione

Canalizzabile (optional)

### Temperatura

+1/+10 °C

### Refrigerante

R404A

### Refrigerazione

Ventilata

### Compressore

Ermetico

### Sbrinamento

Fermata compressore

### Classe Climatica

3

### Vetro superiore

Stratificato riscaldato (disattivabile)

### Vetro frontale

Stratificato riscaldato

### Vetri laterali

Doppio (camera) riscaldato

### Apertura anteriore

Apertura ribaltabile verso il basso

### Chiusura posteriore

Scorrevoli in Plexiglass

### Piano di servizio

- Superficie solida bianca
- Fenix Nero

### Illuminazione

Led 5700 K°

### Movimentazione

Ruote pivotanti con freno e piedini regolabili in altezza



**Front glass**  
Heated stratified

**Vetro frontale**  
Stratificato riscaldato

**Upper glass**  
Heated stratified with switch

**Vetro superiore**  
Stratificato riscaldato (disattivabile)

**Side glasses**  
Heated double

**Vetri laterali**  
Doppi (Camera) riscaldati

		120	170	220
<b>External dimensions (LxDxH)</b> H117		1187 x 1105 x 1170 mm	1682 x 1105 x 1170 mm	2177 x 1105 x 1170 mm
Dimensioni esterne (LxPxH) H135		1187 x 1105 x 1350 mm	1682 x 1105 x 1350 mm	2177 x 1105 x 1350 mm
<b>Capacity (gross/net)</b> H117		685 / 267 lt	1009 / 393 lt	1332 / 518 lt
Capacità (lorda/netta) H135		824 / 267 lt	1212 / 393 lt	1600 / 518 lt
<b>Net weight</b> H117		320 kg	380 kg	410 kg
Peso netto H135		331 kg	390 kg	419 kg
<b>Refrigeration</b> Refrigerazione		<b>Ventilated</b> Ventilata		
<b>Refrigerant</b> Refrigerante		R404A		
<b>Climate class</b> Classe climatica		3		
<b>Operating conditions</b> Condizioni ambientali		25 °C / 60 %RH		
<b>Product temperature</b> Temperatura prodotto		+1/+10 °C		
<b>Compressor (type)</b> Compressore (tipologia)		<b>1 Hermetic</b> 1 Ermetico		
<b>Defrost</b> Sbrinamento		<b>Off Cycle</b> Fermata compressore		
<b>Power supply</b> Alimentazione		230 V / 1 Ph / 50 Hz		
<b>Electrical input (nominal)</b> Assorbimento elettrico (regime)		690 W / 6 A	840 W / 7 A	1230 W / 9 A
<b>Electrical input (defrost)</b> Assorbimento elettrico (sbrinamento)		200 W / 3 A	230 W / 3 A	370 W / 4 A
<small>Technical sheet about models whit condensing unit included with air cooled Dati tecnici riferiti a modelli con unità a bordo con condensazione ad aria</small>				
<b>Setup</b> Allestimento				
<b>Pastry Tray</b> Vassoi pasticceria		•	•	•

	AE45
	1847 x 1105 x 1170 mm
	1847 x 1105 x 1350 mm
	901 / 193 lt
	1082 / 193 lt
	444 kg
	454 kg
	<b>Ventilated</b> Ventilata
	R404A
	3
	25 °C / 60 %RH
	+1/+10 °C
	<b>1 Hermetic</b> 1 Ermetico
	<b>Off Cycle</b> Fermata compressore
	230 V / 1 Ph / 50 Hz
	690 W / 6 A
	200 W / 3 A

### H117

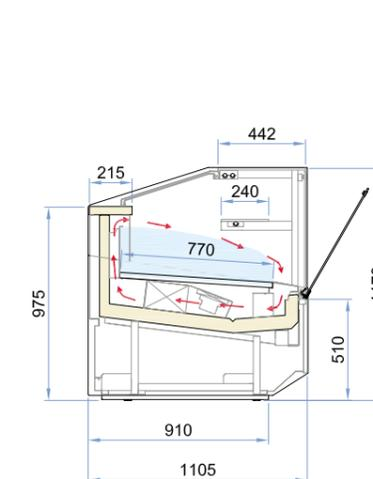

### H135

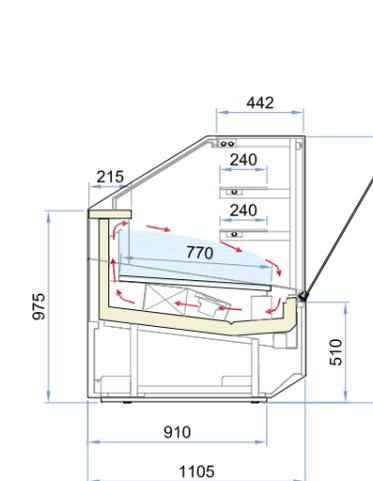

### Available colours - Colori disponibili

- Front panel (1)**  
Pannello frontale
  - RAL on demand
  - RAL 9005
  - Standard / Di serie
- Front grid (2)**  
Griglia frontale
  - RAL 9005
  - Standard / Di serie
- Side panels (3)**  
Fianchi laterali
  - RAL on demand
  - Standard / Di serie





ISA nasce in Umbria, nel cuore di quell'Italia rinomata in tutto il mondo per la sua eccellenza artigianale, industriale e creativa. Con quattro stabilimenti e la presenza in oltre 100 mercati globali ISA è uno dei player al mondo più importanti del mercato dell'arredamento per locali pubblici, delle vetrine e degli armadi refrigerati per gelateria e pasticceria e dell'arredamento professionale.

ISA was established in Umbria, in the heart of Italy, a nation that is famed all over the world for its artisan, industrial and creative excellence. With four sites and the presence in over 100 global markets, ISA is one of the most important players on furniture market for public places, ice cream display cabinets, pastry display cases and professional furniture.

ISA nait en Ombrie, au milieu de cette partie-là d'Italie célèbre dans tout le monde pour son excellence artisanale, industrielle et créative. Avec quatre usines et en étant sur plus de 100 marchés globaux, ISA est un des joueurs les plus importants sur le marché international de l'ameublement pour locaux publiques, de vitrines et d'armoires d'exposition réfrigérées pour glacerie et pâtisserie et de l'ameublement professionnel.

ISA wurde in Umbrien gegründet, im Herzen Italiens, die in der ganzen Welt für ihre handgefertigte, industrielle und kreative Vorzüglichkeit berühmt ist. Mit vier Werkanlagen und dank der Anwesenheit in mehr als 100 ISA Global Märkten, ist ISA einer der wichtigsten Player der weltweiten Möbelmarkt für Lokale, Vitrinen und Kühlschränke für Eisdiele und Konditorei und professionelle Einrichtung.

ISA nace en Umbria, en el corazón de una Italia de renombre en todo el mundo por su artesanía, industria y creatividad excelentes. Con cuatro establecimientos y presente en más de 100 mercados globales, ISA es uno de los principales protagonistas mundiales del mercado del mobiliario profesional y de locales públicos así como de los expositores y refrigeradores para heladería y pastelería.



La ISA S.p.A. nell'ambito del continuo miglioramento del prodotto, si riserva il diritto di modificare in qualsiasi momento, senza preavviso, le caratteristiche tecniche ed estetiche dei propri modelli.

In the interest of continual product improvements, ISA S.p.A. reserves the right to make changes in technical specifications and accessories at any moment and without prior notice.

