

# TWICE THE TOPPING. TWICE THE YUM.

## TWIN TOPPING WARMERS

Warm and dispense two hot toppings from #10 cans or 3 qt (2.8 L) jars – choose from the following dispensing methods:

- (2) stainless steel pumps
- (2) lids and ladles
- (1) lid and ladle, (1) pump

Portion-control pumps provide consistent servings and help manage food costs



Precise temperature control and accurate, even heat eliminates wasted servings – no scorching as product depletes



NSF listed as a rethermalizer – quickly heat toppings to a safe serving temperature



1.800.558.8722  
Server-Products.com



### TWIN TOPPING WARMER

Model Twin FS/FSP, Twin FS & Twin FSP

#### Food Applications

- Warm two sauces, gravies or toppings for dipping, dressing or plating
- Small batch prep maintains ideal freshness
- Great for heating different products that require specific temperature settings

#### Fast Facts

Safely warm sauces, gravies or toppings and serve with a ladle or portion-control pump – max 1 oz (30 mL) stroke adjusts in 1/8 oz (3.7 mL) increments.

Individual thermostats with temp markings control each heating element and use a water-bath to warm each topping. Accurate, even heat prevents scorching and burning.

Add colored, engraved knobs for quick product differentiation – specify when ordering.

Also accepts a squeeze bottle inset with (3) 16 oz squeeze bottles for plating.



86819 inset

TWIN TOPPING WARMERS  
Models Twin FS/FSP, Twin FS & Twin FSP

# TAKE ULTIMATE CONTROL OF TOPPING

## TWIN HOT TOPPING WARMER

Models Twin FS/FSP, Twin FS & Twin FSP

### Specifier Statement

Server Products Twin Topping Warmers Models Twin FS/FSP, Twin FS, and Twin FSP are designed to pump or ladle hot toppings straight from a #10 manufacturer's can or 3 qt (2.8 L) stainless steel jar (not included). Stainless steel water-bath warmers include (2) adjustable thermostats with temperature markings to control individual 500W wrap-around heating elements. Temperatures range from 100°F to 200°F, and power is controlled with (2) switches.

Twin FS/FSP, designed to pump and ladle toppings, includes (1) lift-off lid and 1 oz (30 mL) ladle, and (1) stainless steel pump with 1 oz (30 mL) max stroke adjustable in 1/8 oz (3.7 mL) increments.

Twin FS designed to ladle toppings, includes (2) lift-off lids and (2) ladles.

Twin FSP designed to pump toppings and includes (2) stainless steel pumps.

NSF listed. Rethermalizer. C-UL-US listed. Two-year warranty. Ships FOB Richfield, WI 53076.

### Twin Warmer Product Codes

- Warmer, pump & ladle Twin FS/FSP 81290
- Warmer, (2) ladles Twin FS 81220
- Warmer, (2) pumps Twin FSP 81230

### Specifications

Part Number	Capacity	Dimensions (height x width x depth)	Weight	Electrical
81290		15 5/16" x 17" x 13 1/2" 38.9 x 43.2 x 34.3 cm	18 lb 9.5 kg	
81220	(2) 3 qt Jars (2) 2.8 L Jars	12 5/16" x 17" x 9 5/8" 31.3 x 43.2 x 24.4 cm	17 lb 9.1 kg	120V 1000W 15A
81230		15 5/16" x 17" x 13 1/2" 38.9 x 43.2 x 34.3 cm	19 lb 10 kg	



Plug is NEMA 5-15P with 72" (183 cm) cord

230V models also available



### Accessory Items

Customize an item.

- Stainless steel jar, 3 qt (2.8 L) 94009
- Stainless steel 10" ladle, 1 oz (30 mL) 82561
- Squeeze bottle inset 86819

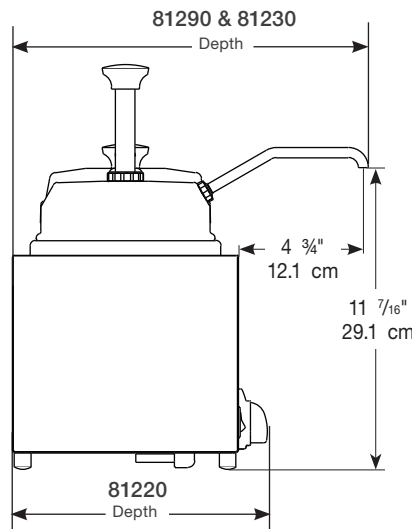
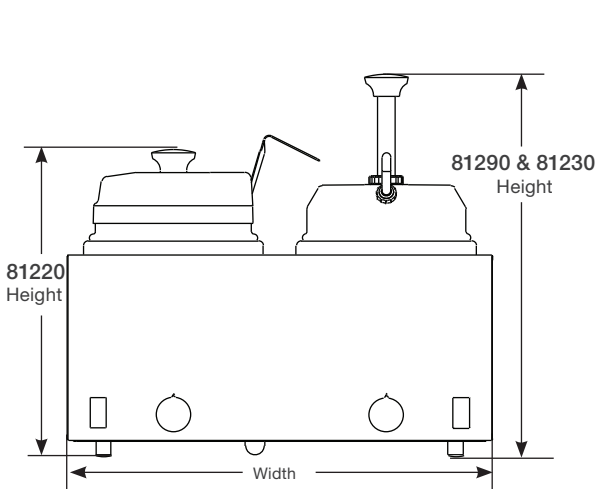

Server Products, Inc. 800.558.8722 | Intl: 262.628.5600  
3601 Pleasant Hill Road | Richfield WI 53076  
spsales@server-products.com | server-products.com

Server Products, Inc. reserves the right to modify specifications without obligation.  
Printed in USA | © Server Products, Inc 01.2019 | S 02051